

Метрическая резьба ISO DIN-13

ISO Metric coarse thread DIN-13



HSS

HSSE

OX

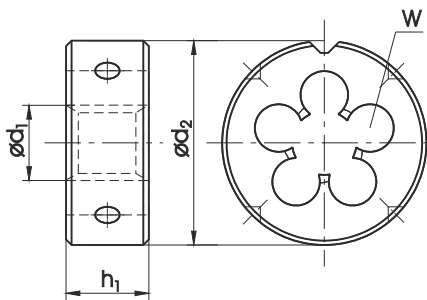

800

800 SPN

INOX



Вид материала / Material groups

P 2+3

P 2+3

P 2+3

N 2

N 2

M 1+2

N 2+3

Исполнение / Execution

HSS

HSS

HSSE

Покрытие / Coating

OX

Сбег резьбы / Chamfer

1,75P

1,75P

2,25P

Точность / Tolerance

6g

6g

6g

M $\varnothing d_1$	P	$\varnothing d_2 \times h_1$	W		INDEX	N1-121001	N1-141001	N2-188001
M 2	0,4	16 x 5	3	1,95	0020	●	●	●
M 2,5	0,45	16 x 5	3	2,42	0025	●	●	●
M 3	0,5	20 x 5	3	2,92	0030	●	●	●
M 4	0,7	20 x 5	3	3,90	0040	●	●	●
M 5	0,8	20 x 7	3	4,90	0050	●	●	●
M 6	1	20 x 7	4	5,88	0060	●	●	●
M 8	1,25	25 x 9	4	7,86	0080	●	●	●
M 10	1,5	30 x 11	4	9,85	0100	●	●	●
M 12	1,75	38 x 14	4	11,83	0120	●	●	●
M 14	2	38 x 14	4	13,82	0140	●	●	●
M 16	2	45 x 18	5	15,82	0160	●	●	●

MF $\varnothing d_1$	P	$\varnothing d_2 \times h_1$	W		INDEX	N1-121001	N1-141001	N2-188001
M 8 x 1	1	25 x 9	4	7,88	0083	●	●	●
M 10 x 1	1	30 x 11	5	9,88	0103	●	●	●
M 10 x 1,25	1,25	30 x 11	4	9,86	0104	●	●	●
M 12 x 1,5	1,5	38 x 10	4	11,85	0125	●	●	●
M 14 x 1,5	1,5	38 x 10	5	13,85	0145	●	●	●
M 16 x 1,5	1,5	45 x 14	5	15,85	0165	●	●	●

Vc (m/min)

P	1-6	1-6	1-6
M			1-5
K			
N	5-10	5-10	5-15
S			

Пример для заказа / Example of order

N1-121001-0030
DIN-EN 22 568 M3 6g HSS 800