

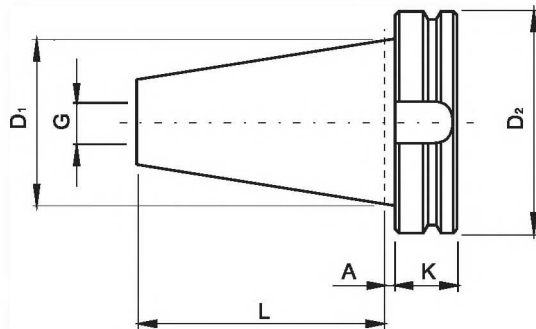

**MAS BT JIS B6339**

Taper	D 1	D 2	L	A	K	G
BT30	31,75	46	48,4	2	22	M12
BT40	44,45	63	65,4	2	27	M16
BT50	69,85	100	101,8	3	38	M24

**Versions:**

- shank without internal cooling
- with a central hole
- with a central hole and the holes in the flange

**Features:**

- Toolholders for machines with automatic tool changing
- For toolholder mounting in the machine are used pull studs
- Toolholders made of nickel-chromium-molybdenum steel, carburized and hardened to 58HRC.
- Surface of taper precision grinded in AT3 class.
- Tool sockets made of 0,007 mm maximum runouts.
- Maximum running speed 10 000 rpm in standard version

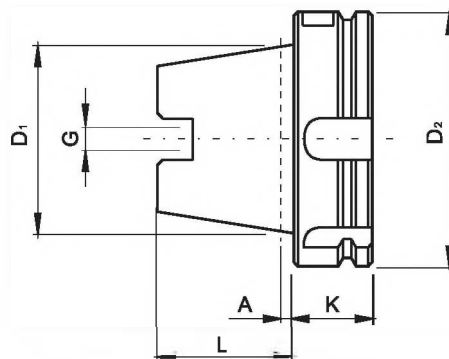
**HSK DIN-69893 A**

Taper	D 1	D 2	L	A	K	G
HSK40	30	40	20	4,0	20	M12x1
HSK50	38	50	25	5,0	26	M16x1
HSK63	48	63	32	6,3	26	M18x1
HSK80	60	80	40	8,0	26	M20x1,5
HSK100	75	100	50	10,0	29	M24x1,5

**Features:**

- Toolholders for machines with automatic tool changing
- Toolholders made of nickel-chromium-molybdenum steel, carburized and hardened to 58HRC.
- Surface of taper precision grinded in AT3 class.
- Tool sockets made of 0,007 mm maximum runouts.
- Body balanced in G6,3/8000rpm class in standard version
- Shank design provides axial positioning accuracy, high rigidity, high torque transfer at high speeds