

Informacje techniczne  
 Technical information

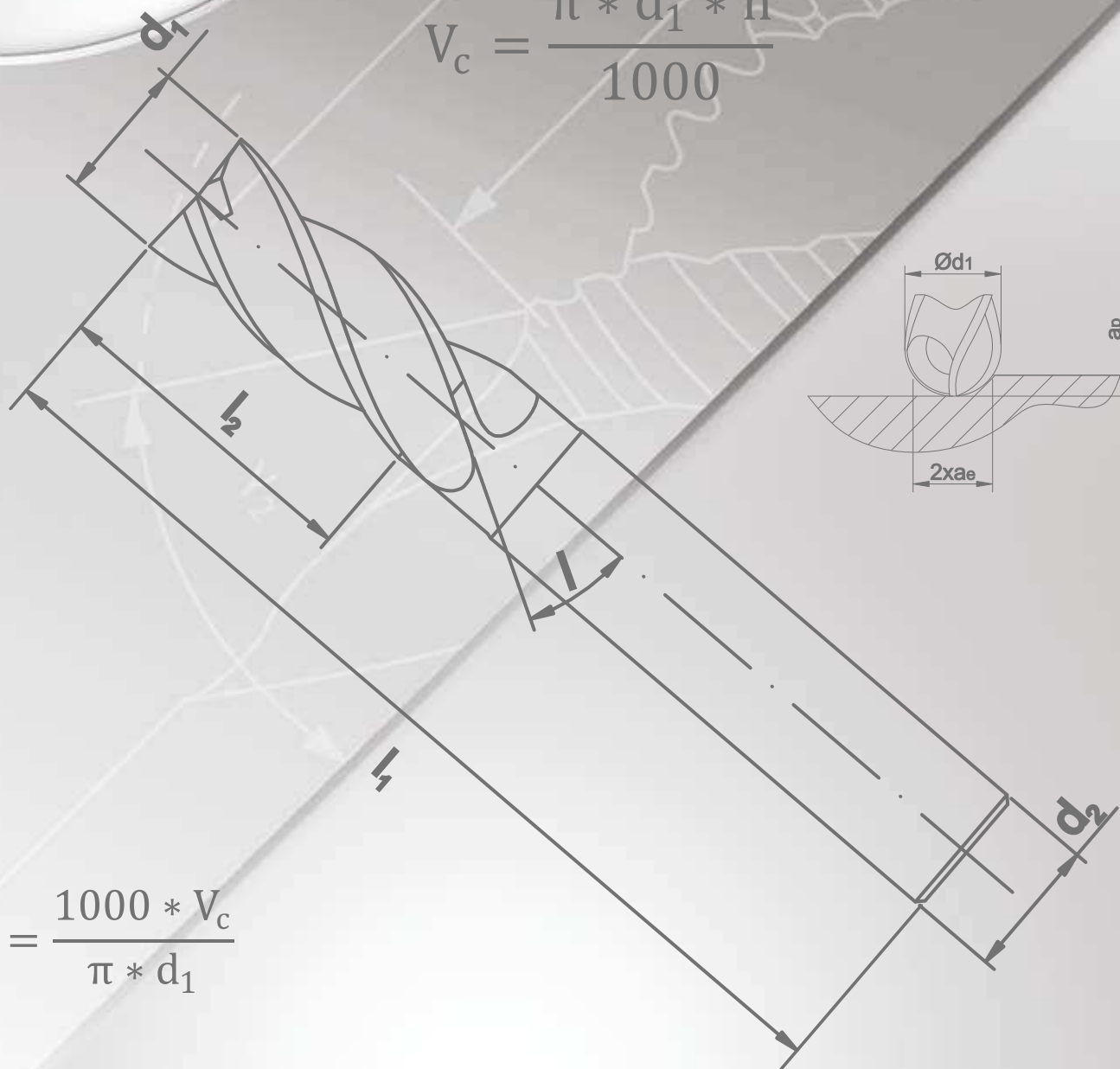

$$V_c = \frac{\pi * d_1 * n}{1000}$$



$$n = \frac{1000 * V_c}{\pi * d_1}$$

$$f = f_z * n * z$$

Parametry skrawania  
 Cutting data